

Errata

Product Manual for Dionex IonPac™ Anion Trap Columns (ATC)

032697-08

For new orders of the following parts discussed in this manual, please use the updated part numbers listed below.

Part	Old Part Number in this manual	Updated Part Number to use for new orders
<i>PROD,COL,IP,ATC-3,4X35MM</i>	<i>059661</i>	<i>079932</i>



PRODUCT MANUAL

IONPAC® ATC-3 2-mm ANION TRAP COLUMN

(4 x 35 mm, P/N 059661)

IONPAC ATC-3 4-mm ANION TRAP COLUMN

(9 x 24 mm, P/N 059660)

IONPAC ATC-HC ANION TRAP COLUMN

(9 x 75 mm, P/N 059604)

QUICKSTART STEPS AND LINKS

Click blue text below to get started.

1. See [Section 2, "Installation and Operation"](#), for details on making required stock and working solutions for eluents. Note operation precautions and chemical purity requirements.

Now sold under the
Thermo Scientific brand

Thermo
S C I E N T I F I C

Part of Thermo Fisher Scientific

©DIONEX Corporation 1997, 1998, 2001, 2002

Document No. 032697

Revision 08

12 July 2002

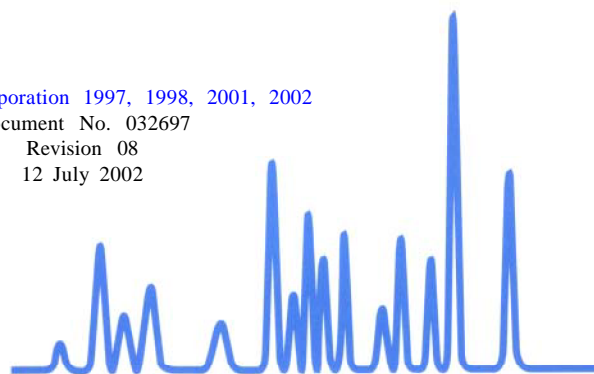

TABLE OF CONTENTS

SECTION 1 - INTRODUCTION	3
SECTION 2 - INSTALLATION AND OPERATION	4
2.1 Chemicals Required	4
2.2 Installation of the IonPac Anion Trap Column	4
2.3 Recommended Operating Pressures	5
2.4 Conditioning the IonPac Anion Trap Column with Hydroxide Eluents	6
2.4.1 Instructions for Using the Analytical Pump for ATC Conditioning	6
2.4.2 Instructions on Using the Trap Column/Suppressor Clean-up Kit for ATC Conditioning	6
2.5 Conditioning the IonPac Anion Trap Column with Borate Eluents	6
2.6 Regeneration/Clean-up of the IonPac Anion Trap Column	7
2.6.1 Regeneration of an Exhausted ATC-3	7
2.6.2 Regeneration of an Exhausted ATC-HC	7
2.7 Column Storage	8
2.7.1 Column Storage for the ATC-3	8
2.7.2 Column Storage for the ATC-HC	8
SECTION 3 - TROUBLESHOOTING GUIDE	9
3.1 High Back Pressure	10
3.2 High Background Conductivity	11

SECTION 1 - INTRODUCTION

The IonPac® Anion Trap Columns (ATC-3 and ATC-HC) contain high capacity microporous anion-exchange resin. The columns strip trace anionic contaminants out of the eluent and/or deionized water and prevent them from reaching the guard and analytical columns. Anionic contaminants present in the eluent and/or deionized water often interfere with the precision of trace anion determinations in particular when performing an anion-exchange application that involves an eluent gradient. The 2-mm ATC-3 (P/N 059661) is designed to be used with 2-mm and 3-mm anion-exchange columns. The 4-mm ATC-3 (P/N 059660) is designed to be used with the 4-mm anion-exchange columns. The ATC-HC (9 x 75 mm) Anion Trap Column (P/N 059604) is specifically designed to be used with IC systems equipped with the EG40 Eluent Generator. This manual describes how to install, regenerate and troubleshoot the ATC-3 and ATC-HC columns.

This manual assumes that you are familiar with the installation and operation of the Ion Chromatograph Systems (IC) and the Anion Suppressors (AMMS, ASRS, and AAES). If you do not understand the operation of the IC system, take the time to familiarize yourself with the various system components before beginning analysis.

Table 1
IonPac ATC-3/ATC-HC Packing Specifications

Column	Particle Diameter µm	Substrate X-Linking %	Substrate Type	Latex Diameter nm	Latex X-Linking %	Column Capacity meq/column	Functional Group	Hydrophobicity
ATC-3 (2-mm)	55	8	microporous	N/A	N/A	0.35	Quaternary Ammonium	Low
ATC-3 (4-mm)	55	8	microporous	N/A	N/A	1.5	Quaternary Ammonium	Low
ATC-HC	750	8	microporous	N/A	N/A	4.0	Quaternary Ammonium	Low

Always remember that assistance is available for any problem that may be encountered during the shipment or operation of DIONEX instrumentation and columns through the DIONEX North America Technical Call Center at 1-800-DIONEX-0 (1-800-346-6390) or through any of the DIONEX Offices listed in, "DIONEX Worldwide Offices."

SECTION 2 - INSTALLATION AND OPERATION

The IonPac Anion Trap Columns (ATC-3 and ATC-HC) are filled with high-capacity microporous anion-exchange resin in the hydroxide form. The primary application of the ATC-3 and ATC-HC columns is to strip anionic contaminants from the hydroxide eluents and/or deionized water used in applications requiring the gradient elution of anions. These contaminants often interfere with the precision of trace level analysis.

The ATC-3 columns are installed in place of the high pressure Gradient Mixer that is normally positioned between the gradient pump pressure transducer and the injection valve.

The ATC-HC column is installed in place of the ATC that is normally positioned between the gradient pump pressure transducer and the inlet of the EluGen-KOH Cartridge located in the EG40 module.

2.1 Chemicals Required

Make sure that all eluents are made with high purity chemicals. Reagent grade inorganic chemicals should always be used to prepare ionic eluents. Whenever possible, inorganic chemicals that meet or surpass the latest American Chemical Society standard for purity should be used. These inorganic chemicals will detail the purity by having an actual lot analysis on each label.

Sodium or potassium hydroxide solutions should always be prepared from a reasonably fresh bottle of 50% w/w or 45% w/w, respectively, that is low in carbonate (Do not use hydroxide stock solutions if a large amount of white sodium or potassium carbonate precipitate is present). **Do not use sodium or potassium pellets to prepare solutions since these pellets readily absorb carbon dioxide from the air.** We recommend you use 50% w/w sodium hydroxide (Fisher Scientific Catalogue No. SS254) with the following purity specifications: iron \leq 5 ppm, chloride \leq 0.005%, and sodium carbonate \leq 0.1% for your sodium hydroxide solutions. And 45% w/w potassium hydroxide (Fisher Scientific Catalogue No. SP236) with the following purity specifications: iron \leq 7 ppm, chloride \leq 0.005%, and potassium carbonate \leq 0.9% for your potassium hydroxide solutions. Concentrated sodium or potassium solutions from other vendors with the same purity specifications may be used.

The deionized water used to prepare solutions in general should be Type I Reagent Grade Water with a specific resistance of 18.2 megohm-cm. The deionized water should be free of ionized impurities, organics, microorganisms and particulate matter larger than 0.2 μ m. Bottled HPLC-Grade Water should not be used since most bottled water contains an unacceptable level of ionic impurities. Finally degas all deionized water prior to preparing any eluent solution.

2.2 Installation of the IonPac Anion Trap Column

- A. Remove the high pressure Gradient Mixer installed between the gradient pump pressure transducer and the injection valve. For the ATC-HC column remove the ATC installed between the pump outlet and the inlet of the EluGen-KOH Cartridge located in the EG40 module. See Figure 1, "System Flow Diagram for Dionex IC Systems Using the ATC-3 Trap Column" and Figure 2, "System Flow Diagram for Dionex IC Systems Using the EG40 Eluent Generator with the ATC-HC Trap Column."
 - B. Connect the line from the gradient pump pressure transducer to the inlet of the conditioned ATC-3 or ATC-HC. Because DIONEX IonPac Trap Columns are not positioned in the analytical pathway (injection valve–analytical columns– suppressor – detector), they can be packed with low efficiency resin and it is not important which end of the trap column is initially designated as the inlet or outlet end of the column. After the trap column is installed in the Ion Chromatograph, it is wise not to reverse the column because the inlet end of the trap column will concentrate both particulates and ionic eluent contaminants. With this in mind, DIONEX places the label under the inlet caps of gradient mixers and ATC-3 columns. (See Section 3.1, "High Back Pressure").
 - C. Connect a short length of liquid line from the outlet port of the ATC-3 or ATC-HC and direct it to a waste container. Condition the ATC-3 or ATC-HC column according to Section 2.4, "Conditioning the IonPac Anion Trap Column with Hydroxide Eluents" or Section 2.5, "Conditioning the IonPac Anion Trap Column with Borate Eluents."
-

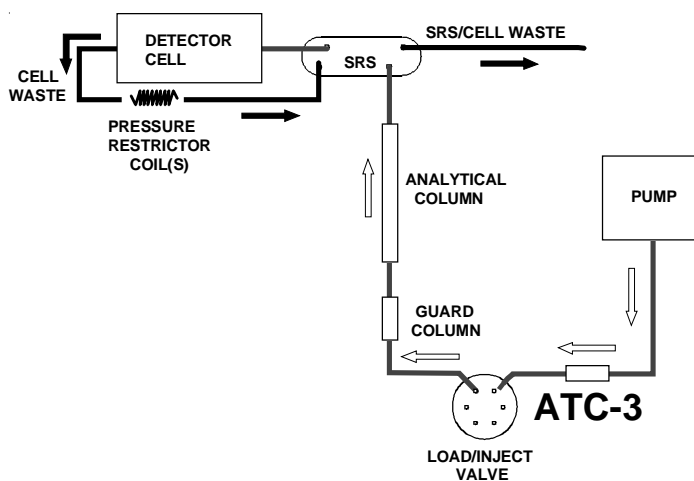

Figure 1
System Flow Diagram for Dionex IC Systems Using the ATC-3 Trap Column

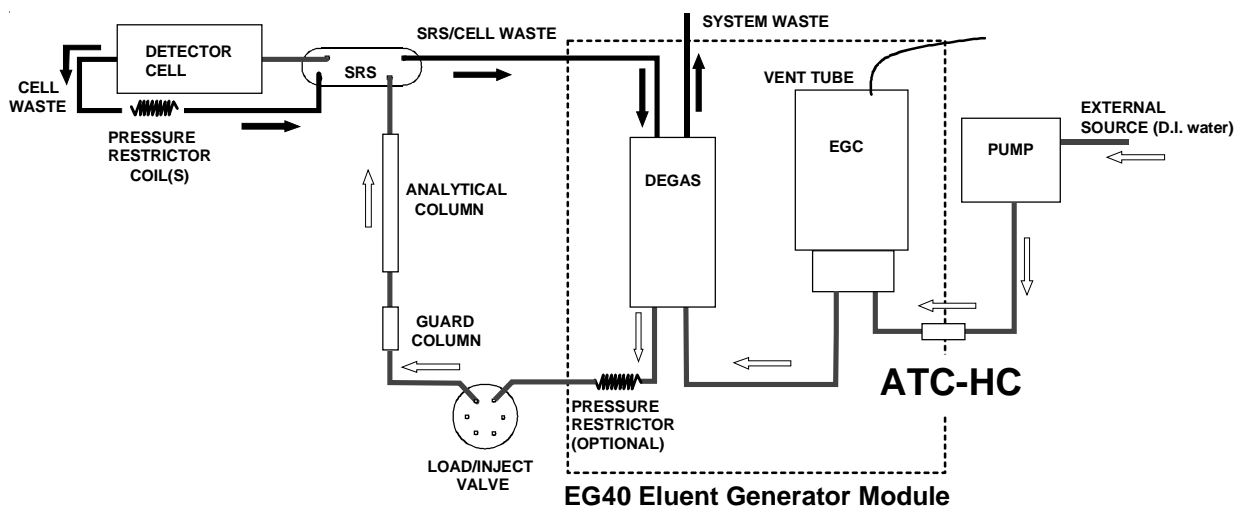

Figure 2
System Flow Diagram for Dionex IC Systems Using the EG40 Eluent Generator with the ATC-HC Trap Column

2.3 Recommended Operating Pressures

The maximum recommended operating pressure for the ATC-3 and ATC-HC is 3,000 psi. Operating a column above its recommended pressure limit can cause irreversible loss of column performance.

2.4 Conditioning the IonPac Anion Trap Column with Hydroxide Eluents

2.4.1 Instructions for Using the Analytical Pump for ATC Conditioning

- A. Prepare a fresh 2.0 M NaOH solution using a 50% w/w NaOH solution available from Fisher Scientific (Catalogue No. SS254) with the following purity specifications: iron \leq 5 ppm, chloride \leq 0.005%, and sodium carbonate \leq 0.1%. Concentrated sodium hydroxide solutions from other vendors with the same purity specifications may be used.
- B. Condition the ATC-3 column by pumping approximately 100 mL of 2.0 M NaOH solution through the 4-mm ATC-3 column or 50 mL for the 2-mm ATC-3 column. Direct the column effluent to a waste container.
- C. Immediately after conditioning the ATC-3 column, pump 20 mL of eluent through the 4-mm ATC-3 or 10 mL for the 2-mm ATC-3 column. Direct the column effluent to a waste container.
- D. After the conditioning of the ATC-3 column, connect the ATC-3 column to the liquid line connected to the inlet port of the injection valve (See Figure 1).
- E. Turn on the IC system and allow it to equilibrate prior to starting your gradient analysis.

2.4.2 Instructions on Using the Trap Column/Suppressor Clean-up Kit for ATC Conditioning

- A. Prepare a fresh 2.0 M NaOH solution using a 50% w/w NaOH solution available from Fisher Scientific (Catalogue No. SS254) with the following purity specifications: iron \leq 5 ppm, chloride \leq 0.005%, and sodium carbonate \leq 0.1%. Concentrated sodium hydroxide solutions from other vendors with the same purity specifications may be used.
- B. Use the Trap Column/Suppressor Clean-up Kit to deliver 100 mL of 2.0 M NaOH solution through the 4-mm ATC-3 column or 50 mL for the 2-mm ATC-3 column. Direct the column effluent to a waste container (See Figure 3).
- C. Install the ATC-3 column in the IC system and pump 20 mL of eluent through the 4-mm ATC-3 or 10 mL for the 2-mm ATC-3 column. Direct the column effluent to a waste container.
- D. After rinsing the ATC-3 column with eluent, connect the ATC-3 column to the liquid line connected to the inlet port of the injection valve (See Figure 1).
- E. Turn on the IC system and allow it to equilibrate prior to starting your gradient analysis.

2.5 Conditioning the IonPac Anion Trap Column with Borate Eluents

- A. Using the Trap Column/Suppressor Clean-up Kit, run through the new or exhausted 4-mm ATC-3 column approximately 200 mL of 70 mM $\text{Na}_2\text{B}_4\text{O}_7$ (100 mL for the 2-mm ATC-3 column). Direct the column effluent to a waste container (See Figure 3).
 - B. Remove the high pressure Gradient Mixer installed between the pump outlet and the injection valve.
 - C. Install the ATC-3 column in the IC system by connecting the line from the gradient pump pressure transducer to the ATC-3 column inlet port (the end of the column with the attached column label). Connect a liquid line from the outlet port of the ATC-3 column and direct it to a waste container.
 - D. Condition the ATC-3 column by pumping approximately 20 mL of eluent through the 4-mm ATC-3 column or 10 mL for the 2-mm ATC-3 column.
 - E. After the conditioning of the ATC-3 column, connect the ATC-3 column outlet to the liquid line connected to the inlet port of the injection valve (See Figure 1).
 - F. Turn on the IC system and allow it to equilibrate prior to starting your gradient analysis.
-

2.6 Regeneration/Clean-up of the IonPac Anion Trap Column

2.6.1 Regeneration of an Exhausted ATC-3

Under normal operating conditions, the ATC-3 column should be regenerated at the end of each operational day to remove any contaminants that may have collected on it, including carbonate. The daily regeneration of the ATC-3 column ensures that the IC system is systematically equilibrated for the most reproducible determinations of those anions being eluted by the weak eluents. Use the Dionex Trap Column/Suppressor Clean-up Kit (P/N 059659) for the regeneration of the ATC-3 column (see Figure 3, "Regeneration of an IonPac Trap Column Using the Trap Column/Suppressor Clean-up Kit"). Refer to Document No. 031835 "Product Manual for the Trap Column/Suppressor Clean-up Kit" for complete installation and operation instructions. Alternatively, the regeneration solution can be pumped using the analytical pump.

A. Regeneration to the Hydroxide Form

1. Prepare a fresh 2.0 M NaOH solution from a 50% w/w NaOH solution (Fisher Scientific No. SS254). Concentrated potassium hydroxide solution (Fisher Scientific No. SP236) may also be used.
2. Use the Trap Column/Suppressor Clean-up Kit or the Analytical Pump to pump 100 mL of 2.0 M NaOH solution through the 4-mm ATC-3 column or 50 mL for the 2-mm ATC-3 column. Direct the column effluent to a waste container (see Figure 3, "Regeneration of an IonPac Trap Column Using the Trap Column/Suppressor Clean-up Kit").
3. Install the ATC-3 column in the IC system and pump 20 mL of eluent through the 4-mm ATC-3 or 10 mL for the 2-mm ATC-3 column. Direct the column effluent to a waste container.
4. After rinsing the ATC-3 column with eluent, connect the ATC-3 column to the liquid line connected to the inlet port of the injection valve.
5. Turn on the IC system and allow it to equilibrate prior to starting your gradient.

B. Regeneration to the Borate Form

Follow the steps described in Section 2.4.2, "Conditioning with Borate Eluents."

2.6.2 Regeneration of an Exhausted ATC-HC

Under normal operating conditions the ATC-HC column has sufficient capacity to continuously remove trace anionic contaminants present in the deionized water for an extended period of time (greater than one month) if the quality of the deionized water used for the eluent is 18.2 megohm-cm. The ATC-HC column should be regenerated when the total background conductivity during the hydroxide gradient is greater than 1.0 μ S. The regeneration of the ATC-HC column restores the column to the hydroxide form and its ability to remove anionic contaminants from the deionized water.

Use the Dionex Trap Column/Suppressor Clean-up Kit (P/N 059659) or the Analytical Pump for the regeneration of the ATC-HC column (see Figure 3, "Regeneration of an IonPac Trap Column Using the Trap Column/Suppressor Clean-up Kit"). Refer to Document No. 031835, "Product Manual for the Trap Column/Suppressor Clean-up Kit," for complete installation and operation instructions.

- A. Prepare a fresh 2.0 M KOH solution from a 45% w/w KOH solution (Fisher Scientific No. SP236). Concentrated sodium hydroxide solution (Fisher Scientific No. SS254) may also be used.
- B. Use the Trap Column/Suppressor Clean-up Kit or the Analytical Pump to pump 200 mL of 2.0 M KOH solution through the exhausted ATC-HC column (see Figure 3, "Regeneration of an IonPac Trap Column Using the Trap Column/Suppressor Clean-up Kit").
- C. Install the ATC-HC column in the IC system and pump 50 mL of deionized water through the ATC-HC column at a flow rate of 2-3 mL/min. Direct the column effluent to a waste container.

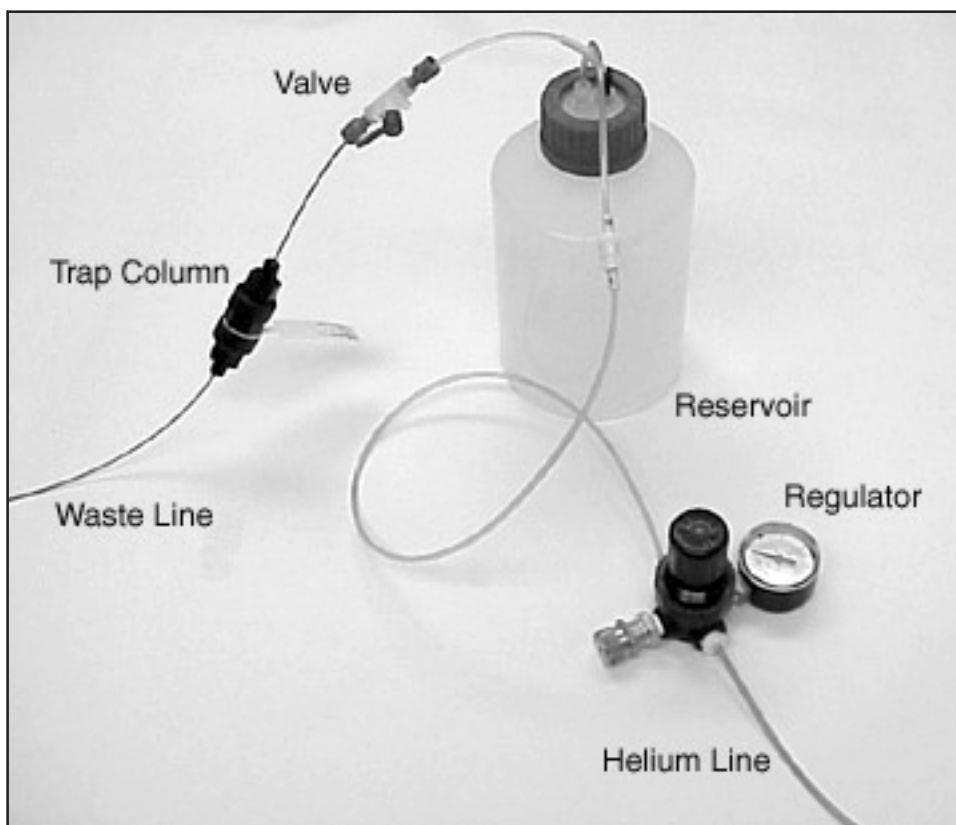

Figure 3

Regeneration of an IonPac Trap Column Using the Trap Column/Suppressor Clean-up Kit

- D. After rinsing the ATC-HC column with deionized water, connect the ATC-HC column to the inlet of the EluGen Cartridge located in the EG40 module.
- E. Turn on the IC system and allow it to equilibrate prior to starting your gradient analysis.

2.7 Column Storage

The ATC-3 and ATC-HC columns are shipped with resin in the hydroxide form with deionized water as the storage solution.

2.7.1 Column Storage for the ATC-3

The ATC-3 columns should be stored in the regenerated form (hydroxide or borate form) with deionized water as the storage solution.

- A. For hydroxide eluents, follow steps A and B, Section 2.6.1, "Regeneration of an Exhausted ATC-3." For borate eluents, follow steps A and B, Section 2.5, "Conditioning with Borate Eluents."
- B. Rinse the 4-mm ATC-3 column with 20 mL of deionized water or the 2-mm ATC-3 column with 10 mL. When completed plug the column inlet and outlet ports.

2.7.2 Column Storage for the ATC-HC

The ATC-HC column should be stored in the regenerated form (hydroxide form) with deionized water as the storage solution.

- A. Follow steps A to C, Section 2.6.2, "Regeneration of an Exhausted ATC-HC." When completed plug the column inlet and outlet ports.

SECTION 3 - TROUBLESHOOTING GUIDE

The purpose of the Troubleshooting Guide is to help you solve operating problems that may arise while using IonPac ATC-3 or ATC-HC columns. For more information on problems that originate with the Ion Chromatograph (IC), the Anion Suppressor (ASRS, AMMS, AAES), the EG40 Eluent Generator System, refer to the Troubleshooting Guide in the appropriate operator's manual. If you cannot solve the problem on your own, contact the nearest DIONEX Office (see, "DIONEX Worldwide Offices").

Table 2
ATC-3/ATC-HC Troubleshooting Summary

Observation	Cause	Action	Reference Section
High Back Pressure	Unknown	Isolate Blocked Component	3.1
	Plugged Column Bed Supports	Replace Bed Supports	3.1
	Other System Components	Disconnect, Replace	Component Manual
High Background Conductivity	Bad Eluents	Remake Eluents	3.2
	Contaminated Columns	Clean Column	3.2
	Contaminated ASRS, AMMS or AAES	Clean Suppressor	Component Manual
	Contaminated Hardware	Clean Component	Component Manual

3.1 High Back Pressure

If the ATC-3 or ATC-HC is the cause of high back pressure, its inlet bed support may be contaminated. To change the bed support follow the instructions below using one of the two spare bed supports included in the Ship Kit.

- A. Disconnect the ATC-3 or ATC-HC from the Ion Chromatograph.
- B. Using two open-end wrenches, carefully unscrew the inlet (the end of the column with the attached column label for the 4-mm ATC-3) column end fitting.
- C. Turn the end fitting over and tap it against a bench top or other hard, flat surface to remove the bed support assembly. If the bed support must be pried out of the end fitting, use a sharp pointed object such as a pair of tweezers, but be careful that you do not scratch the walls of the end fitting. Discard the old bed support assembly.
- D. Place a new bed support assembly into the end fitting. Carefully screw the end fitting onto the column so that the seal washer seats properly between the end fitting and the end of the column.

CAUTION

If the column tube end is not clean when it is inserted into the end fitting, particulate matter may prevent a proper seal between the end of the column tube and the bed support assembly. If this is the case, additional tightening may not seal the column but instead damage the column tube or the end fitting.

- E. Screw the end fitting onto the column until it is finger tight and then using wrenches, tighten it an additional 1/4 turn (25 in x lb). Tighten further only if leaks are observed.
- F. Reconnect the ATC-3 or ATC-HC to the Ion Chromatograph and resume operation.

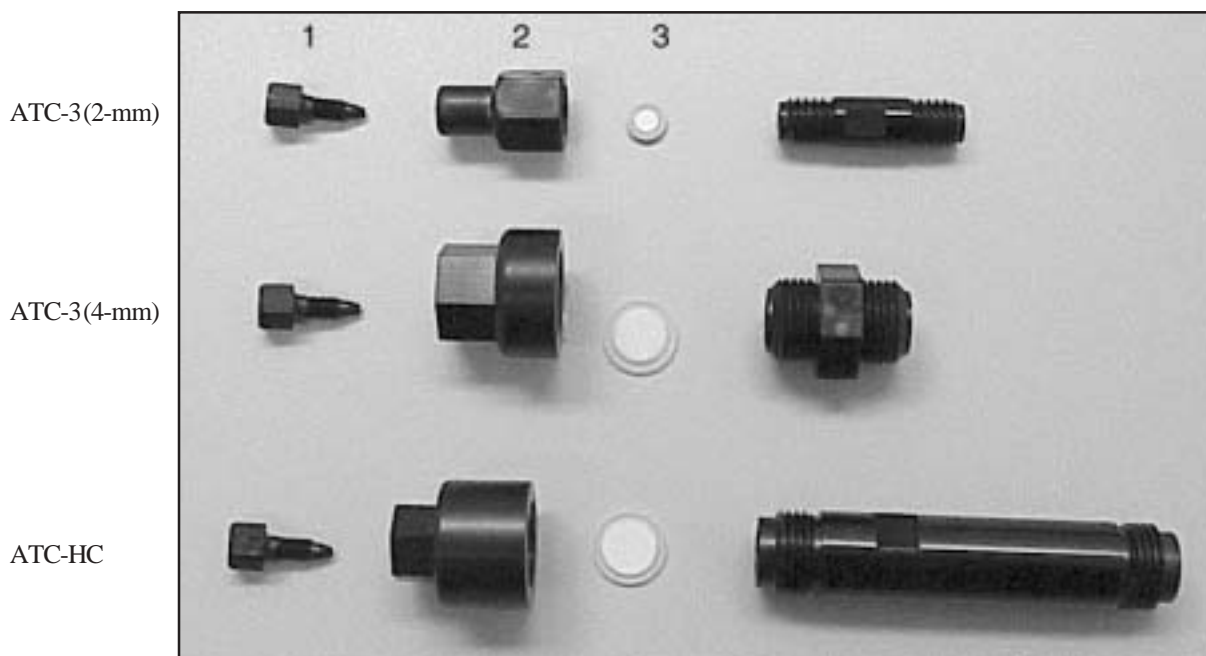

Figure 4
IonPac Anion Trap Hardware Configurations

Table 3
ATC-3/ATC-HC Component Summary

Column Line Description	Item No.	Assembly P/N	Component Description
ATC-3(2-mm)	1	042772	Plug Fitting
	2	052809	End Column Fitting
	3	042955	Assembly Bed Support
ATC-3(4-mm)	1	042772	Plug Fitting
	2	045287	End Column Fitting
	3	060270	Assembly Bed Support
ATC-HC	1	042772	Plug Fitting
	2	048298	End Column Fitting
	3	048238	Assembly Bed Support

3.2 High Background Conductivity

In a properly working system, you should expect to observe the background conductivities listed in Table 4, “ATC-3/ATC-HC Expected Background Conductivity Summary.” Background conductivities will not change if solvents are added to the above eluents. Determine the source of the high background by following the steps below.

Table 4
ATC-3/ATC-HC Expected Background Conductivity Summary

Trap Column	Eluent	Expected Background Conductivity	
		Bottled Eluents	EG40 KOH Eluents
ATC-3	0.75 mM NaOH	1-3 μ S	$\leq 1 \mu$ S
ATC-3	40 mM NaOH	2-4 μ S	$\leq 1 \mu$ S
ATC-3	80 mM NaOH	4-7 μ S	$\leq 1 \mu$ S
ATC-3	70 mM $\text{Na}_2\text{B}_4\text{O}_7 \cdot 10\text{H}_2\text{O}$	10-15 μ S	N/A
ATC-HC	0.1 - 100 mM KOH	N/A	$\leq 1 \mu$ S

- A. Check the eluent composition. Were the eluents formulated correctly and did the chemicals used to make them have the required purity (see Section 2.1, “Chemicals Required”)? The eluents must be made from high purity deionized water that is sparged and free from dissolved carbon dioxide. The eluents must be made from concentrated 50% hydroxide solution that meets the specified purity. The 50% hydroxide reagent must have no carbonate precipitate content. The presence of carbonate will decrease the time between ATC-3 or ATC-HC regenerations. Overloading of the ATC-3 or ATC-HC with carbonate will elevate the background conductivity and increase baseline shifts during gradient operation.

- B. Is the ATC-3 or ATC-HC installed in front of the injection valve in the analytical flow path (see Section 2.2, “Installation of the IonPac Anion Trap Column”)? If the background conductivity is high when the ATC-3 is not installed in the system between the gradient pump pressure transducer and the injection valve (or between the pressure transducer of the gradient pump and the inlet of the EluGen-KOH Cartridge for the ATC-HC), the eluent contains measurable anionic contaminants and is the source of the high background conductivity. Check the DI water source and hydroxide reagents for carbonate contamination. If a new ATC-3 or ATC-HC or a freshly regenerated ATC-3 or ATC-HC (see Section 2.2, “Installation of the IonPac Anion Trap Column”) is installed and the background conductivity decreases, the ATC-3 or ATC-HC is effectively trapping contaminants from the eluent.
- C. If an ATC-3 or ATC-HC is installed in the system, remove it and observe the background conductivity. If the eluent is freshly prepared with high purity chemicals and if the background conductivity decreases when the ATC-3 or ATC-HC is removed, then the ATC-3 or ATC-HC is the source of the background conductivity and needs to be regenerated or replaced. To regenerate an ATC-3 or ATC-HC that is overloaded with contaminants, follow the steps in Section 2.5 “Regeneration Clean-up of the IonPac Anion Trap Column.”
- D. If the background conductivity is not within the expected ranges (see Table 4, “ATC-3/ATC-HC Expected Background Conductivity Summary”) when the freshly regenerated ATC-3 is installed between the pressure transducer of the gradient pump and the injection valve (or between the pressure transducer of the gradient pump and the inlet of the EluGen-KOH Cartridge for the ATC-HC), replace the ATC-3 or ATC-HC.
-